

APPLICATIONS

- Test holes
- Micropiles
- Anchoring
- Jet grouting
- Water wells
- Restoration work

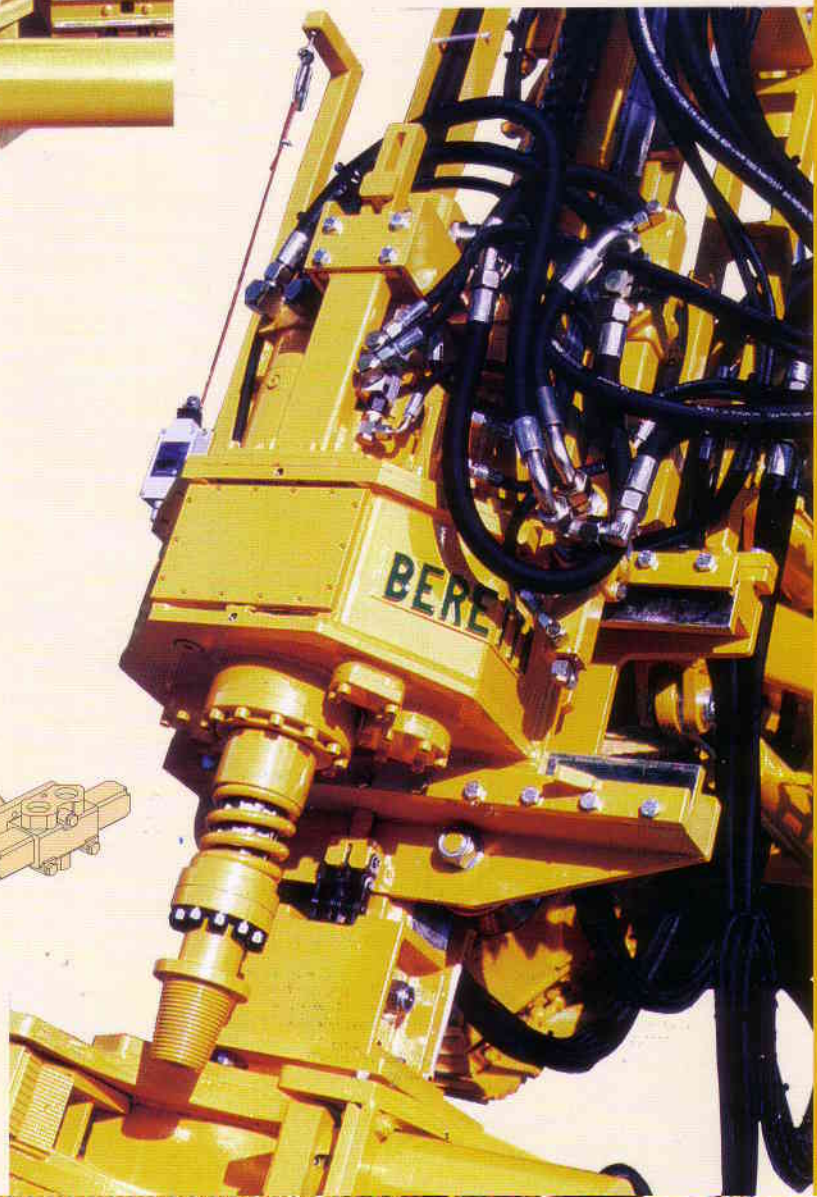
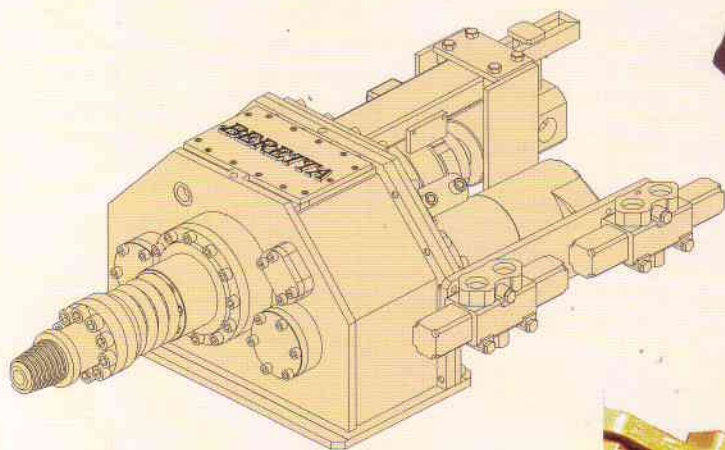

Hydraulic Rotary Head for T51 - T52 - T53 - T57 - T59

BERETTA[®]

56-4V

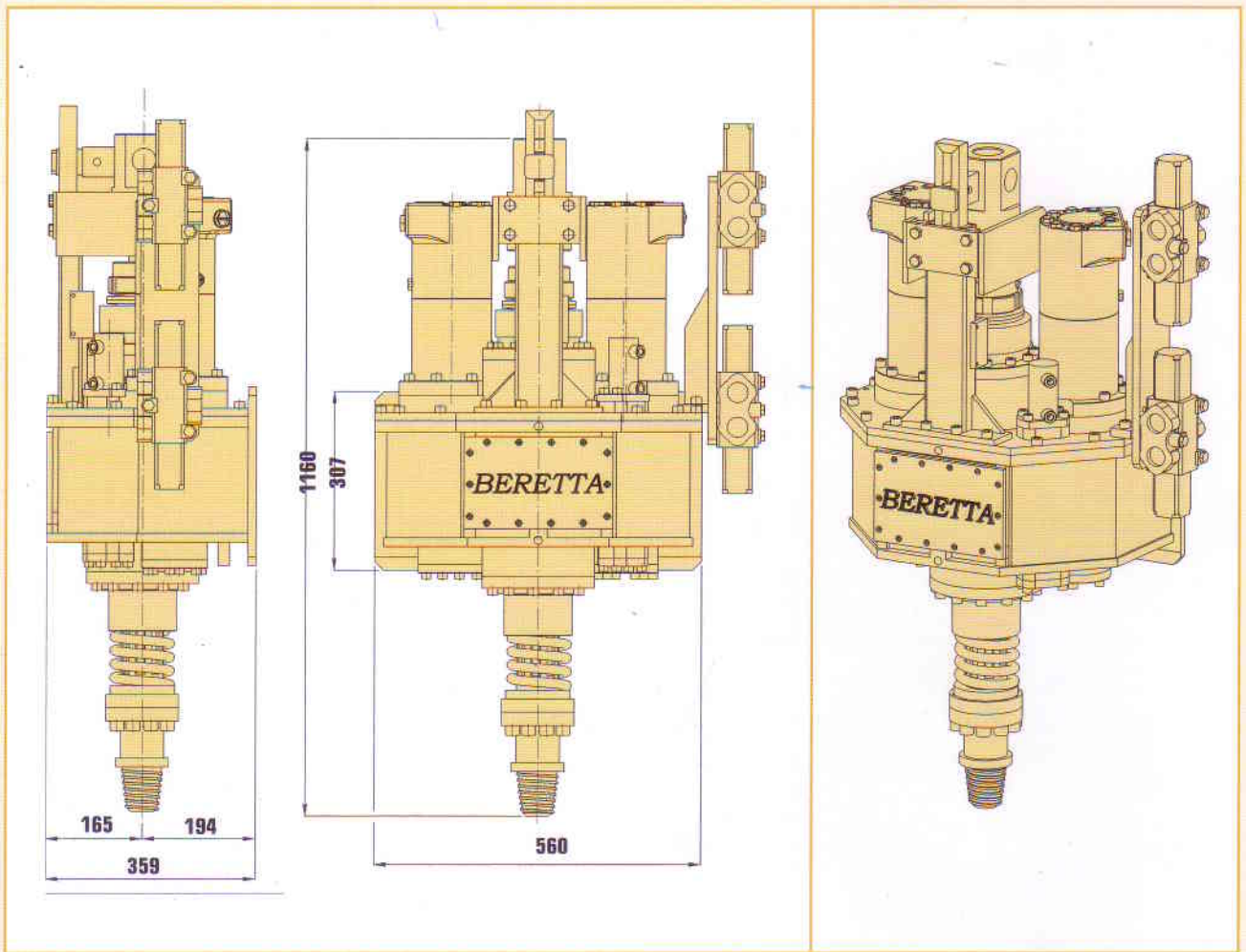

Weight = **345 Kg - 761 lb**

Inside diameter for jet grouting = **62 mm - 2,44 in**

Max oil Feed = **125 l/min - 33,02 gal/min**

Max working pressure = **280 Bar - 3982 PSI**

Rotary head for: **T51 - T53 - T57 - T59 hydraulic drilling machine**

Tecnologia		SPEED	TORQUE (daNm)	TORQUE (lb ft)	RPM (n/min)
		A	1°	805	5833
2°	403		2920	132	
3°	206		1493	259	
4°	103		746	519	
B	1°	1046	7580	51	
	2°	523	3790	102	
	3°	267	1935	200	
	4°	133	964	400	

BERETTA migliora costantemente i suoi prodotti riservandosi il diritto di apportare qualsiasi modifica senza preavviso nè responsabilità
 BERETTA continuously improves its products reserving the right to modify data without advance notice decling any responsibility
 Revisione depliant N. 3 - Aprile 2011 / Brochure revision N. 3 - Aprile 2011



Beretta Alfredo s.r.l.

20842 BESANA IN BRIANZA (MB) - ITALIA - Via Vignareto, 10
 Tel. +39 (0)362 99.53.80 r.a. - Fax +39 (0)362 99.57.08
 www.berettaalfredo.it - e.mail: info@berettaalfredo.it



ISO 9001 - Cert n. 1323